



Identification of Electron Cyclotron Resonance Heating (ECR) Surfaces in the UPPR-Plasma Device Operating in the Cusp and Mirror Mode.

David Leal Escalante and Franklyn Colmenares Ochoa,
Mechanical Engineering, PUPR

Mentors: Dr. Angel Gonzalez and Dr. Edbertho Leal
NASA Puerto Rico Space Grant Consortium
PR-LSAMP



What's Plasma

- Fourth state of matter.
- Influenced by the electrical interaction of the ions and electrons and by the presence of magnetic fields.
- Plasma is the most abundant form of matter in the universe (99%).

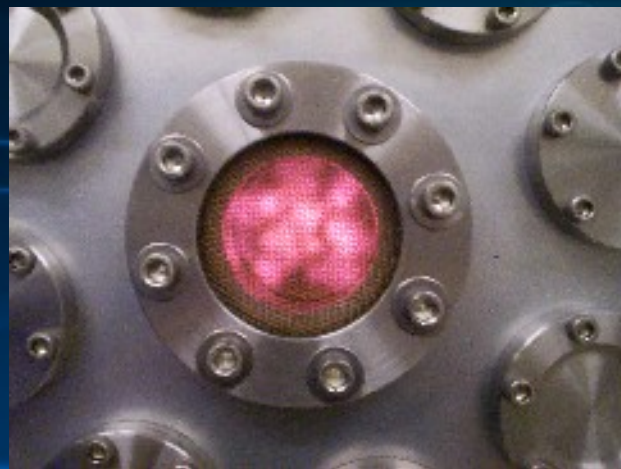

Plasma applications

- Fusion confinement.
- Surface treatment.
- Waste disposal.
- Propulsion systems.

UPPR-plasma machine

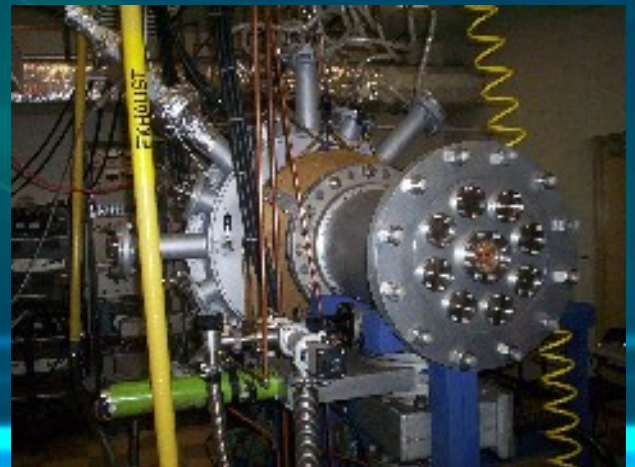

Methodology

Vacuum system:
2. Rotary pumps.

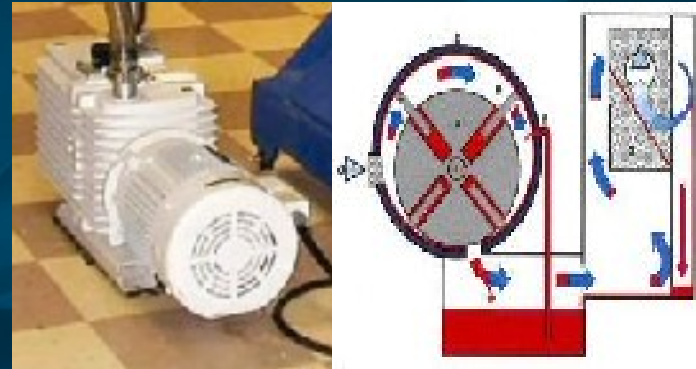

5. Diffusion Vacuum Pump.



- # Magnetic Field Activation:
2. Mirror & Cusp fields mode.
 3. Power supply of coils
 4. Microwave

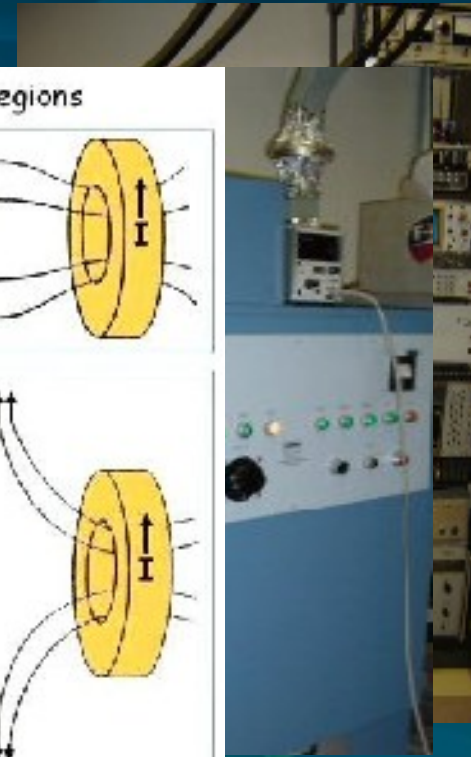
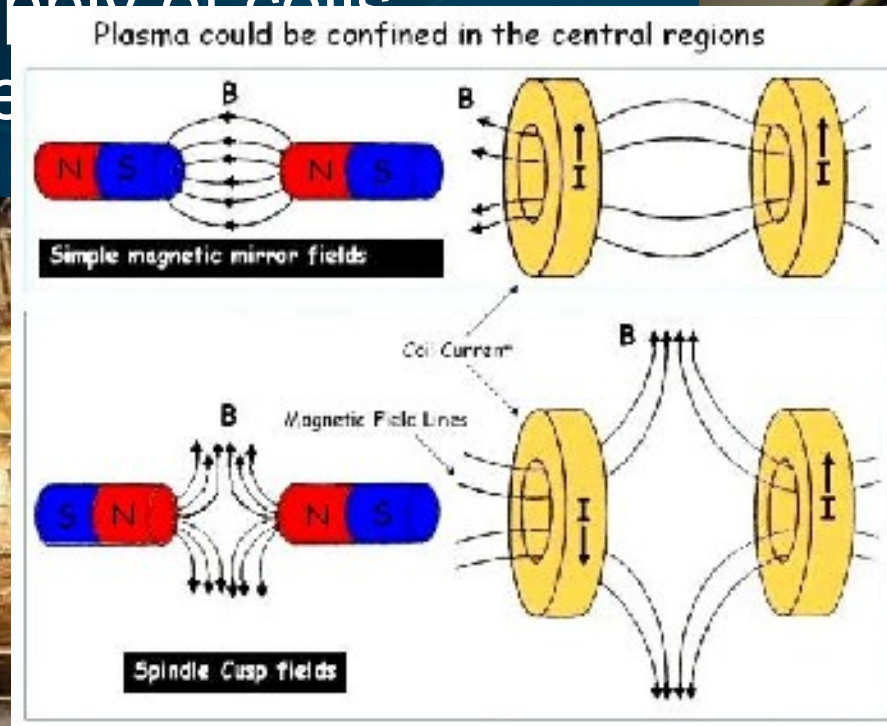

Resonance frequency

- In order to produce plasma with microwave power, it is necessary to have a resonance frequency between the magnetron frequency of the high power microwave source and the cyclotron frequency.
- This cyclotron frequency is a result of the circular movement of the electrons in the external magnetic field formed utilizing two large Helmholtz Coils.

Resonance frequency

- The effect of both these frequencies in the chamber ionizes the gas and creates plasma.
- The heating source is a variable high power microwave generator from 50 watts to 5,000 watts at a frequency of 2.45 GHz.

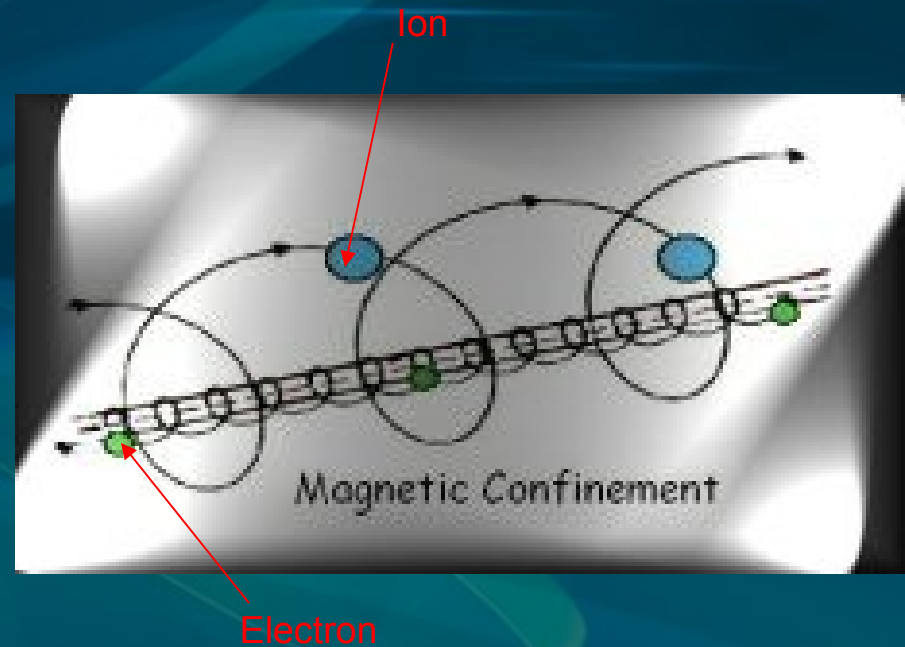

Investigation

- The goal of this research project is to identify the adequate magnetic field surfaces at the *PUPR-Plasma machine* that have a magnitude value in which resonance will be present when the plasma machine is operating in the Mirror Mode and in the Cusp Mode.
- Utilizing a Hall Probe 2100 Gauss meter, several Magnetic Field Measurements are taken by varying the probe location in longitudinal and radial coordinates.

Investigation

- **After the data is collected utilizing a variation of the electrical current generated by the power supply in the Helmholtz Coils, a comparison can be made of the results experimentally obtained with data from a Matlab calculation of the field vector coordinates utilizing the magnetic flux in the volume between the Helmholtz coils utilizing the equation.**

Measuring the magnetic field

1. Connect the Gaussmeter 2100 and Insert the magnetic hall probe into the chamber.
2. Turn on the power supply.
3. Readings are taken in the long distance from the center of the machine every 2 cm. The same procedure is followed for every 2 cm. The same procedure is followed for every 2 cm of the machine.



Plasma Machine Diagram

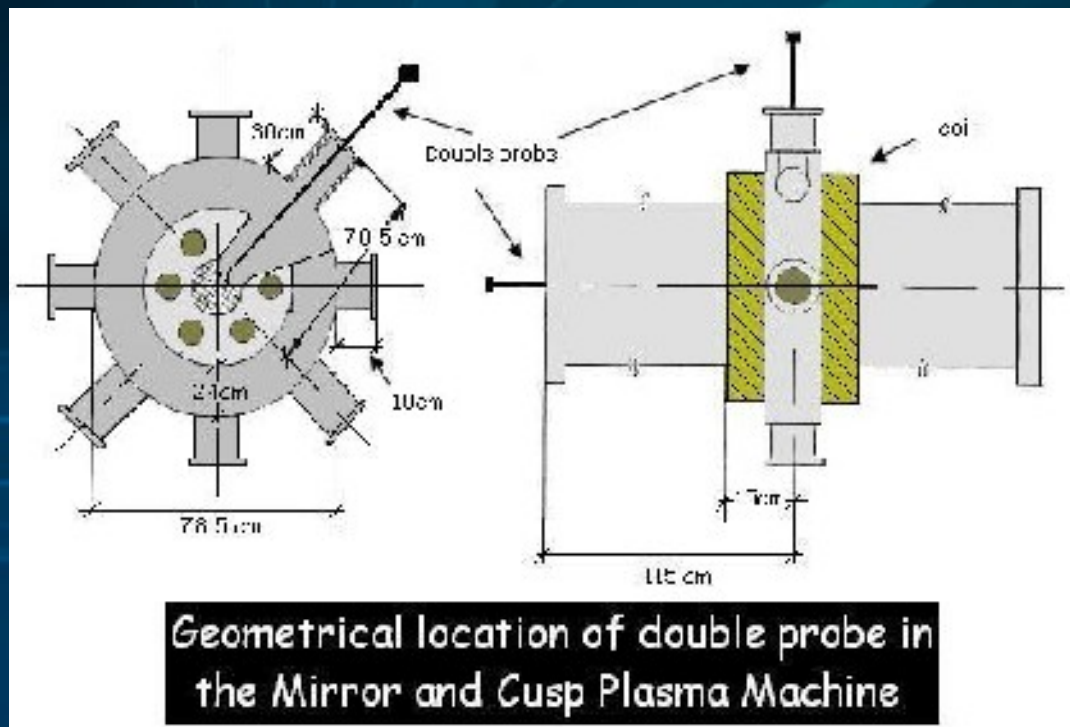

Magnetic Field Equations

<http://www.netdenizen.com/emagnet/helmholtz/Image107.gif>

$$G = \frac{1}{\sqrt{2\pi(a^2 - (\beta_2 - \beta_1))}} \left[\begin{aligned} & + (\gamma - \beta_2) \ln \frac{a - \sqrt{a^2 + (\gamma + \beta_2)^2}}{1 + \sqrt{1 + (\gamma + \beta_2)^2}} \\ & - (\gamma - \beta_1) \ln \frac{a + \sqrt{a^2 + (\gamma - \beta_1)^2}}{1 + \sqrt{1 + (\gamma - \beta_1)^2}} \\ & + (\gamma - \beta_1) \ln \frac{a + \sqrt{a^2 + (\gamma - \beta_1)^2}}{1 + \sqrt{1 + (\gamma - \beta_1)^2}} \\ & + (\gamma - \beta_2) \ln \frac{a - \sqrt{a^2 + (\gamma - \beta_2)^2}}{1 + \sqrt{1 + (\gamma - \beta_2)^2}} \end{aligned} \right]$$

G = Unit less Geometric Factor

Magnetic Field Equations

Magnetic Flux in the volume between a Helmholtz Coil pair:

$$B_x = \mu_0 \sqrt{\frac{P\lambda}{r\rho}} G$$

μ = Permeability

λ = flux linkage

ρ = Resistivity

P = Power

r = radius

G = Unit less geometry factor

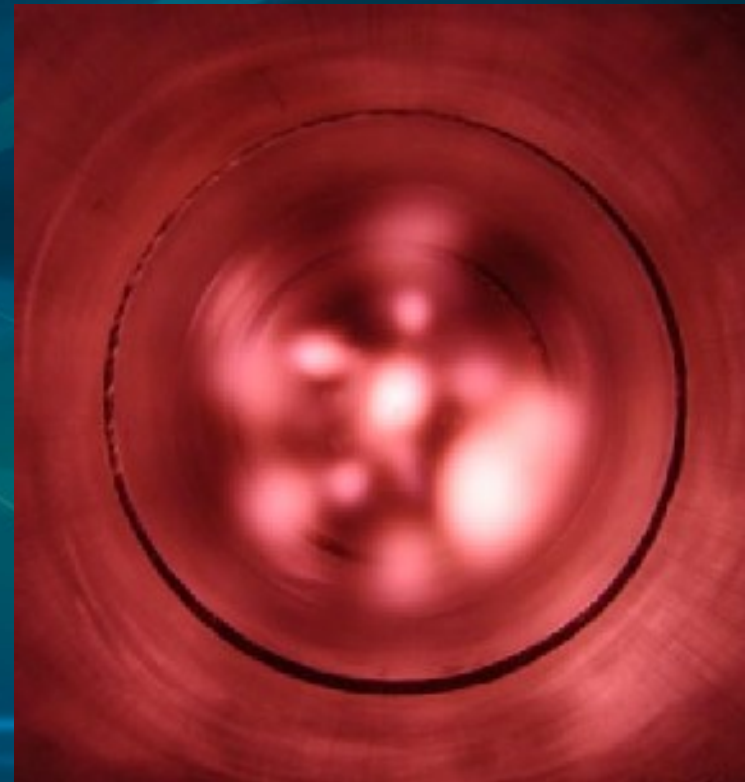

Magnetic Field Results

- Due to many variables and data measurements necessary to establish the correct parameters needed to obtain the magnetic resonance frequency experimentally, high precision is needed in the control of the Hall Probe.
- Repeating measurements at each location would allow for mean values to be obtained, in such way that a comparison between the experimental results and the theoretical values can be performed.
- By increasing the current in the coils, the magnetic field magnitude also increased at each location.

Magnetic Field Results

- **By using the Hall probe it was found that the resonance field can be greater than 875 Gauss, which is the minimum field amount necessary for plasma formation in both modes.**
- **Utilizing Matlab software, a precise graph can be made of each mode of the machine, both in CUSP and in MIRROR mode, similar to the figures below. By understanding the shape and intensity of the magnetic field formed, the magnetic confinement of the plasma can be obtained.**

Magnetic Field Graphs

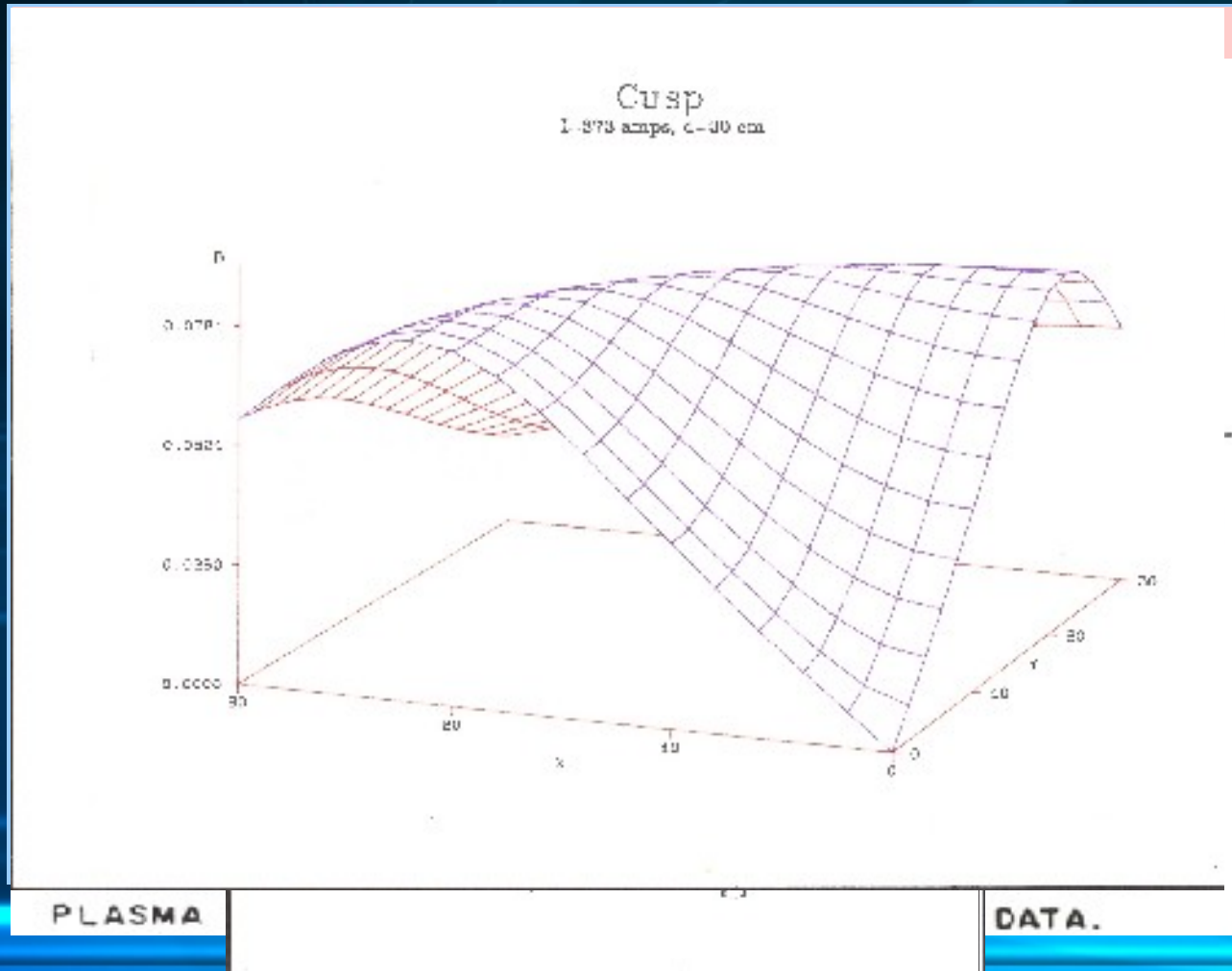

Conclusion

- In conclusion, we can determine that the resonance field can be greater than 875 Gauss, which is the minimum field amount necessary for plasma formation in both modes.
- Obtaining the optimum magnetic field in the machine is crucial to creating useful plasmas.

Conclusion

- Utilizing the mathematical equations, the ideal cyclotron frequency can be obtained, allowing for the formation of higher density plasmas useful for surface treatment of materials, energy analysis, and fusion research.

Future Work

- **More in depth experimentation is necessary with the Hall Probe in order to gather more data at each point, allowing for a more precise mean value of field magnitude at each point that can be graphed.**

Acknowledgments

- TVI
- NASA Puerto Rico Space Grant
 - Dr. Ángel González
 - Dr. Edbertho Leal
 - Ing. Ryan Meyer



Questions?